

Pflaster - Asphalt: Kl. A - C
pavement - asphalt: cl. A - C

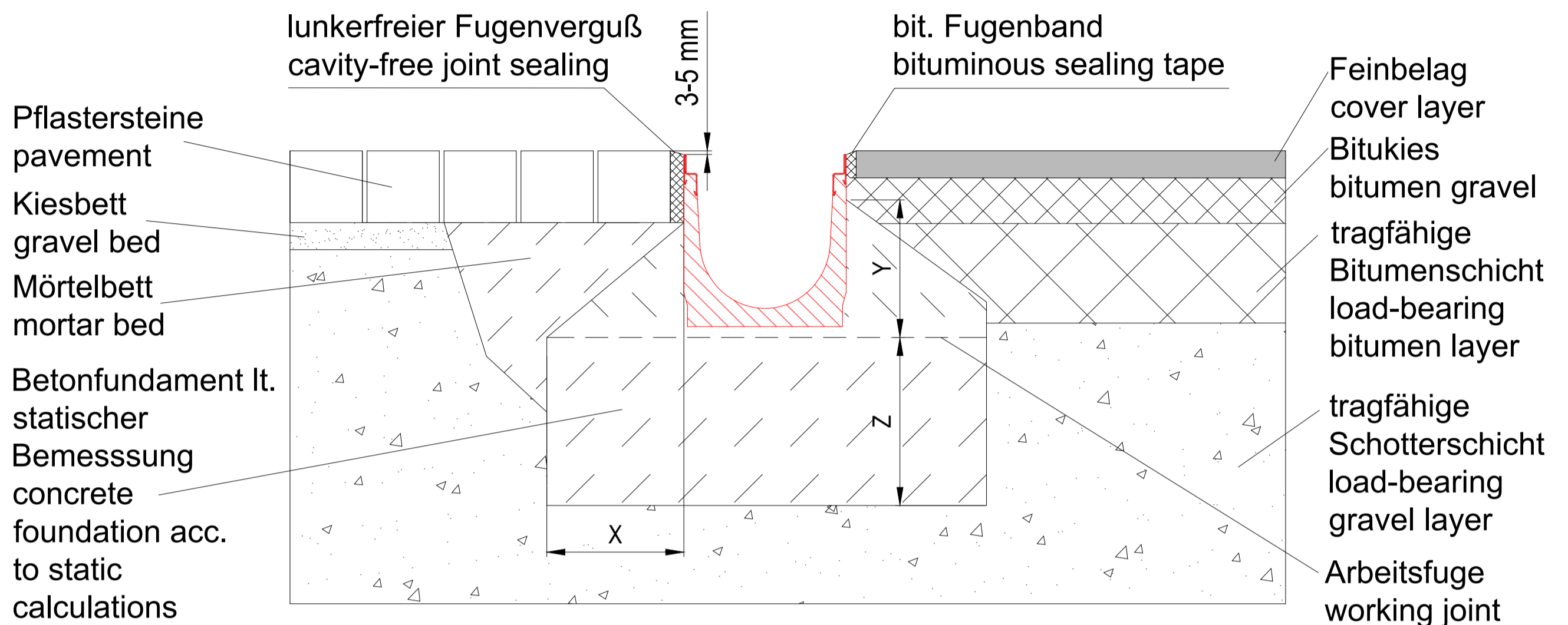

Asphalt - Bordstein: Kl. C
asphalt - kerbstone: cl. C

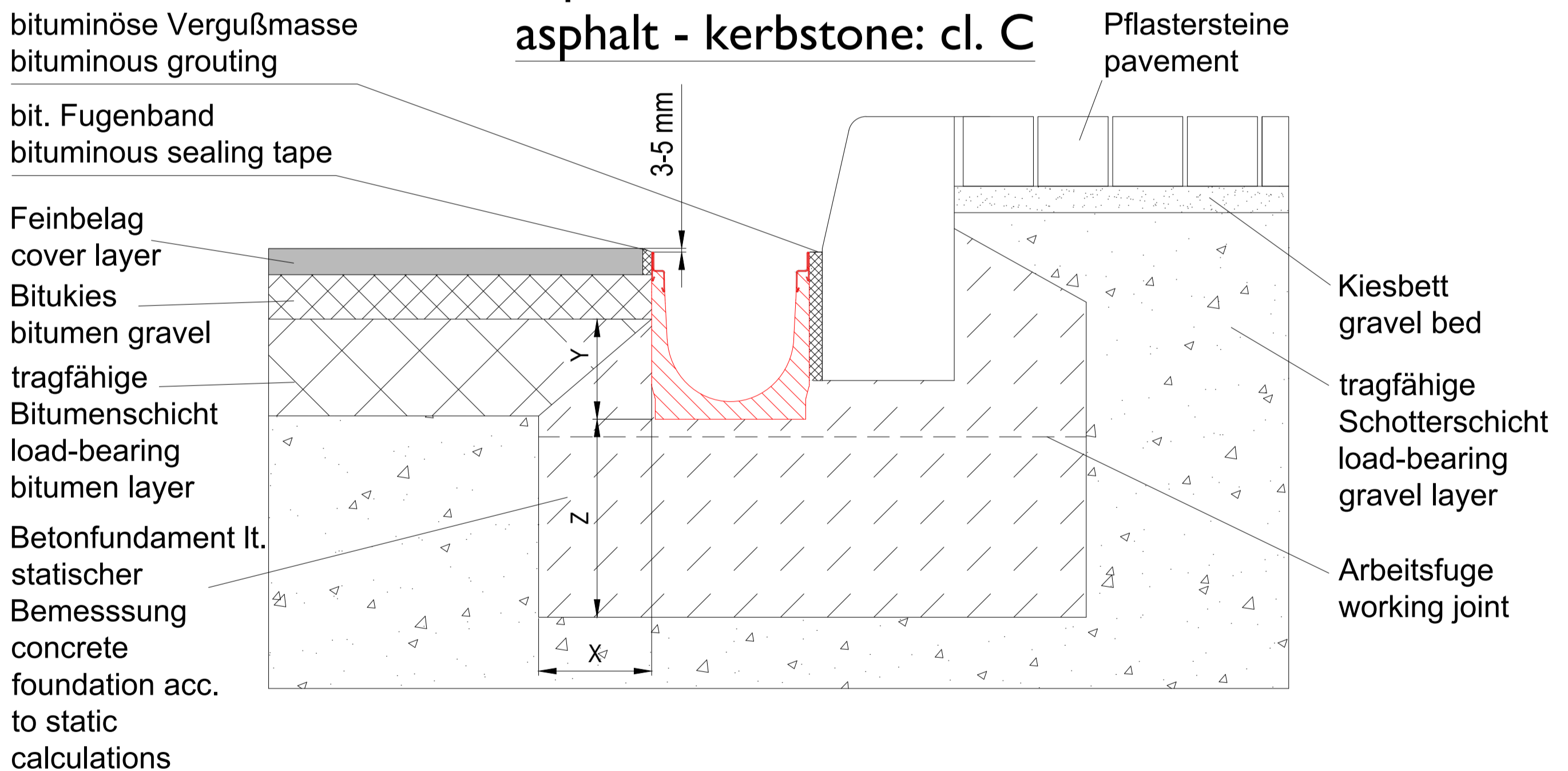

Belastungsklasse/load class	A 15 kN	B 125 kN	C 250 kN
Betongüte - Fundament gem. / concrete quality acc. to Ö-Norm B4710-1*	C 16/20	C 20/25	C 20/25
Breite: / width: X	≥ 8 cm	≥ 10 cm	≥ 15 cm
Höhe: / height: Y	Rinnenhöhe / channel height - 5 cm (mini - 3 cm)		
Stärke / thickness: Z	≥ 8 cm	≥ 10 cm	≥ 15 cm
Steckeisen / reinforcement bar	nicht erforderlich / unnecessary		
* Betongüte ist eine Mindestanforderung und den örtlichen Anforderungen anzupassen. * Concrete quality is a minimum requirement and has to be adapted to the local conditions.			

Asphalt - Asphalt: Kl. A-C
asphalt - asphalt: cl. A-C

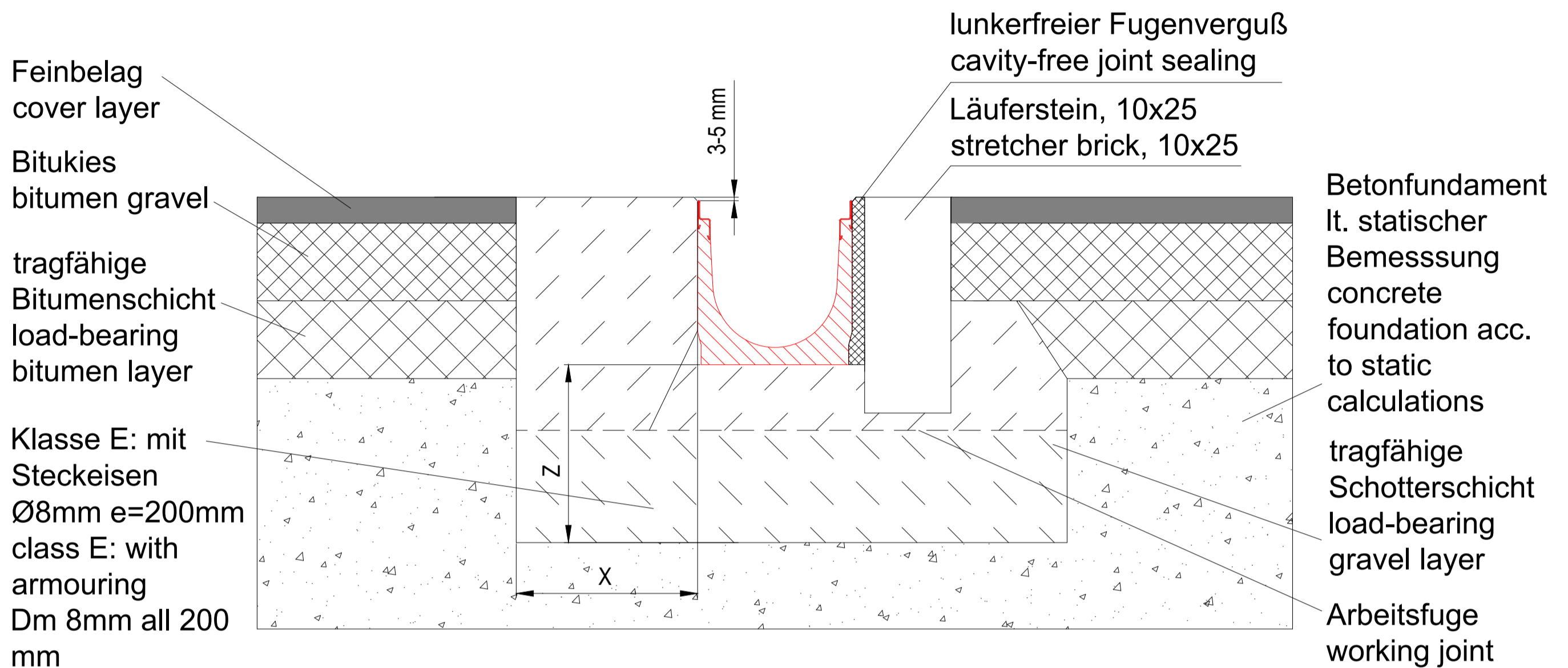

Beton - Beton: Kl. A-C
concrete - concrete: cl. A-C

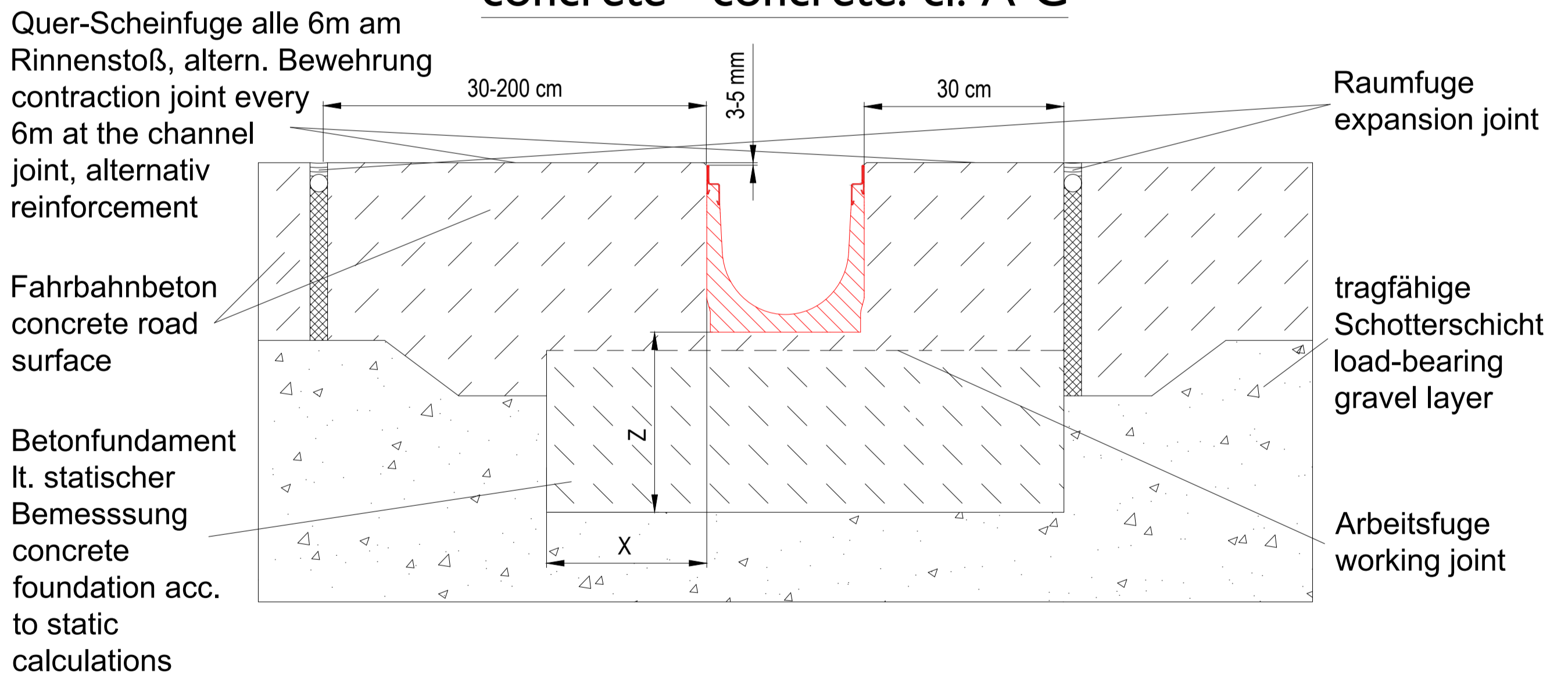

Belastungsklasse/load class	A 15 kN	B 125 kN	C 250 kN
Betongüte - Fundament gem. / concrete quality acc. to Ö-Norm B4710-1*	C 16/20	C 20/25	C 20/25
Breite: / width: X	≥ 8 cm	≥ 10 cm	≥ 15 cm
Höhe: / height: Y	Rinnenhöhe / channel height - 5 cm (mini - 3 cm)		
Stärke / thickness: Z	≥ 8 cm	≥ 10 cm	≥ 15 cm
Steckeisen / reinforcement bar	nicht erforderlich / unnecessary		
* Betongüte ist eine Mindestanforderung und den örtlichen Anforderungen anzupassen. * Concrete quality is a minimum requirement and has to be adapted to the local conditions.			